



HotLok® Blanking Panels

Part Numbers

- 10114 1U 19" White Blanking Panel (10 pack)
- 10115 2U 19" White Blanking Panel (5 pack)
- 10031 1U 19" Black Blanking Panel (10 pack)
- 10033 2U 19" Black Blanking Panel (5 pack)
- 10177 1U 23" Black Blanking Panel (10 pack)

Part Numbers - Gaylord Packs

- 10221 1U 19" Black Blanking Panel (1104 pack)
- 10222 1U 19" White Blanking Panel (1104 pack)
- 10224 2U 19" Black Blanking Panel (528 pack)
- 10225 2U 19" White Blanking Panel (528pack)

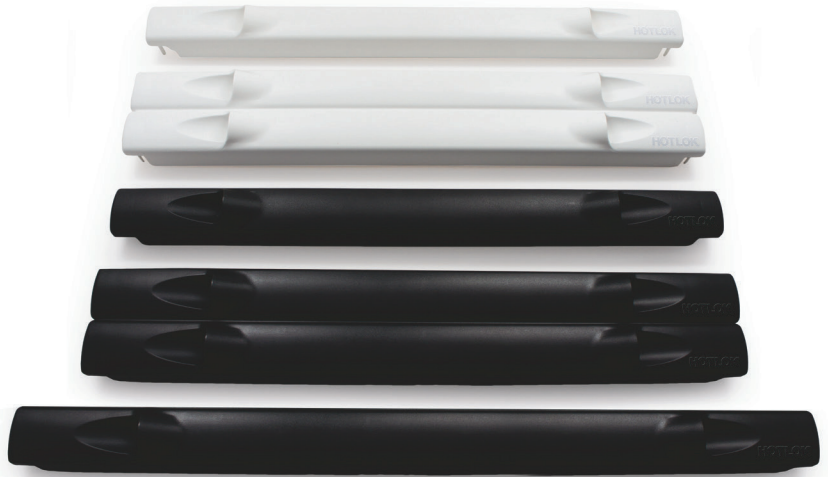

Applications

Designed to effectively seal openings in IT equipment cabinets and control airflow for optimized cooling effectiveness. The HotLok Blanking Panel reduces hotspots and bypass airflow by preventing equipment exhaust air or hot aisle air from migrating to the conditioned air intake stream at the front of the cabinet. HotLok Blanking Panels are available in both 1U and 2U configurations and a choice of traditional black or a more reflective white.

The white blanking panels are available to coordinate with white racks and enclosures for improved aesthetics. In addition, they are engineered to offer light reflectance properties for energy savings by increasing the reflectivity in the server cabinet and reducing the amount of lighting required. At normal data center lighting levels, the white blanking panel offers 3.5 times the reflectance of a standard black blanking panel. This means more brilliancy in the data center and better illumination of surrounding surfaces and computer cabinets.



Features

- Cantilevered sealing vanes eliminate the gap between adjoining blanking panels or with installed equipment to provide the most effective sealing blanking panel on the market, a seal 29% better than the nearest competitor
- Tool-free, snap-in installation requires no additional parts or components for installation
- Ergonomic finger grips built in to allow easy-pull removal in standard EIA-310-E openings
- Interlocking design allows secure stacking (1U panels stack 10 high and 2U panels stack 20 high) for easy storage and convenient carrying, supporting the best practice of keeping particulates and contaminants like cardboard boxes out of the data center
- Compliant with Directive 2002/95/EC of the European Parliament and the Council on the Restriction of the Use of Certain Hazardous Substances in the Electrical and Electronic Equipment (RoHS)

Benefits

- Allows lower temperature air to be delivered to the upper one-third of the cabinet, typically the hottest area and most prone to equipment failure
- Use in a Hot and Cold Aisle configuration for low or high density cabinets
- Controls airflow that could lead to saved energy by allowing adjustment of cooling unit set points
- Use in existing cabinets for optimization and standardization
- 1U and 2U versions available for EIA-310-E compliant cabinets

Specifications

Part Number	Description	Dimensions	Quantity	Shipping Weight
10114	1U White Blanking Panel	19" x 1.75" (482.5 mm x 44.5mm)	10	3 lbs.
10115	2U White Blanking Panel	19" x 3.5" (482.5 mm x 89 mm)	5	3 lbs.
10031	1U Black Blanking Panel	19" x 1.75" (482.5 mm x 44.5mm)	10	3 lbs.
10033	2U Black Blanking Panel	19" x 3.5" (482.5 mm x 89 mm)	5	3 lbs.
10177	1U Black Blanking Panel	23" x 1.75" (584.2 mm x 44.5mm)	10	5 lbs.
10221	1U 19" Black Blanking Panel Gaylord Pack	49" X 46" X 36" (1245mm x 1168mm x 914mm)	1104 1U's Per Pack	385 lbs.
10222	1U 19" White Blanking Panel Gaylord Pack	49" X 46" X 36" (1245mm x 1168mm x 914mm)	1104 1U's Per Pack	385 lbs.
10224	2U 19" Black Blanking Panel Gaylord Pack	49" X 46" X 36" (1245mm x 1168mm x 914mm)	528 2U's Per Pack	385 lbs.
10225	2U 19" White Blanking Panel Gaylord Pack	49" X 46" X 36" (1245mm x 1168mm x 914mm)	528 2U's Per Pack	385 lbs.

Patented Rack Sealing System

U.S. design patent number D577,360 and multiple International design patents. U.S. and International utility patents pending.

Materials

High Impact Polystyrene
UL 94 HB Fire Rating
150°F (65.6°C) Maximum Operating Environment

1U Blanking Panel

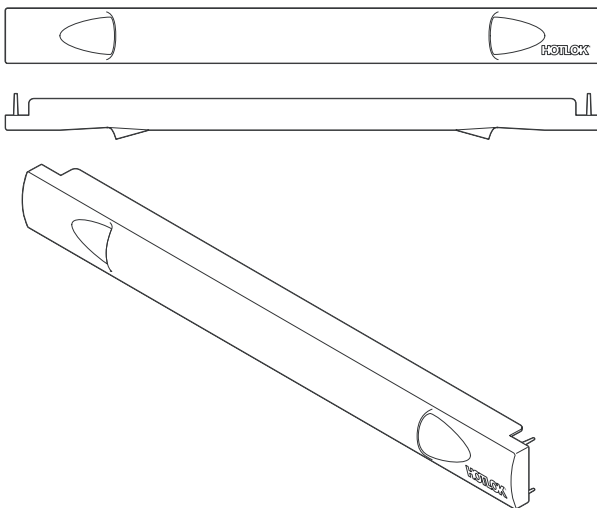

2U Blanking Panel

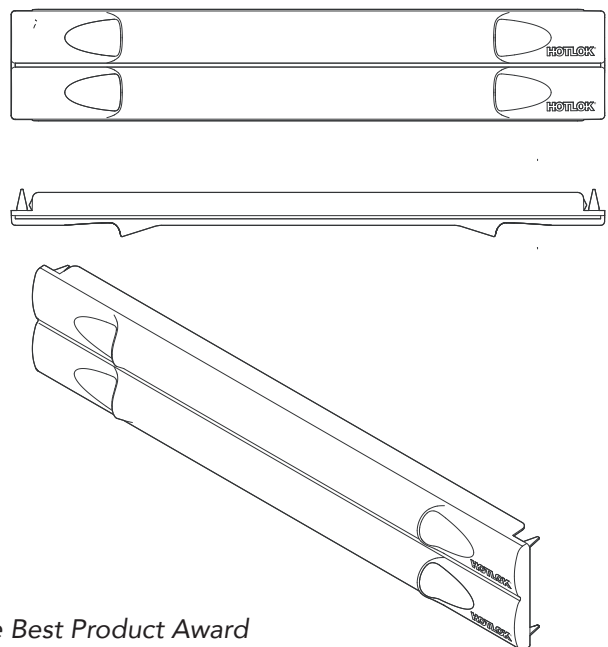

upsite
technologies®

Designer and Manufacturer
888.982.7800
www.upsite.com



Winner of the Best Product Award
in the Infrastructure category.
Searchdatacenter.com