

HOTLOK®



HotLok® Switchfix

Part Number

SF001-PR5 1U 12.75"-21" (324mm - 533mm) Black



Applications

The SwitchFix easily solves cooling problems associated with network switches without the need for additional energy usage. It allows your switches to benefit from cooler airflow and comply with Hot Aisle/Cold Aisle best practices.

Network switch equipment typically sits at the top and back portion of the server rack. This placement makes it difficult for cold air from the cold aisle to travel from the front of the rack to the intake side(s) of the Network Switch. The SwitchFix solves this problem by extending from the front of the rack in the cold aisle to the switch at the back of the rack. This allows cold air from the cold aisle to reach the network equipment for proper cooling

The SwitchFix comes in a variety of sizes to meet the needs of many switches currently used in today's data centers. Each unit adjusts in depth to ensure an optimal flow of cooled air through to the installed switch. The SwitchFix easily accommodates front, rear, and side switch intakes and exhaust. The SwitchFix's passive airflow system channels air from the cold aisle to the switch, allowing cold air to pass through the switch intakes and prevents bypass and recirculated airflow. This prevents hot exhaust air from recycling through the installed equipment. This passive switch cooling solution can improve switch performance and life expectancy.

Features

- Channels cold air to the switch
- Prevents hot air recirculation
- Maintains cold aisle/hot aisle segregation
- Adjustable for a variety of depths
- Passive airflow circulation

Benefits

- Maintains switch reliability and improves longevity of the switch
- Augments and improves upon airflow management best practices
- Switchfix line supports over 200 switches in a passive application or 150 switches in an active* application
- No additional power supply is required for the passive units
- Supports 1U and 2U switches**

**Active units are available upon request*

***Visit Upsite.com for a purchasing guide to determine which SwitchFix meets your needs*

Specifications

Part Number	Description	Dimensions	Quantity per Carton	Shipping Weight
SF001-PR5	Passive, Switch Rear Intake, 1U, Adjustable, Black	12.75"-21" (324mm - 533mm)	1	21 lbs.

Airflow

Passive (switch generated)

Switch Intake

Supports switches with rear to front air intakes

Materials

18 Guage Galvanized Steel
RoHS Compliant
Black Powder Coated Finish

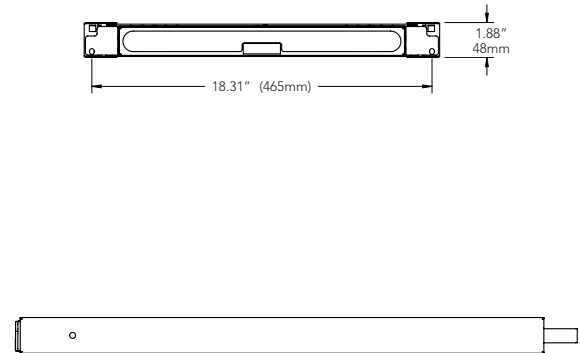
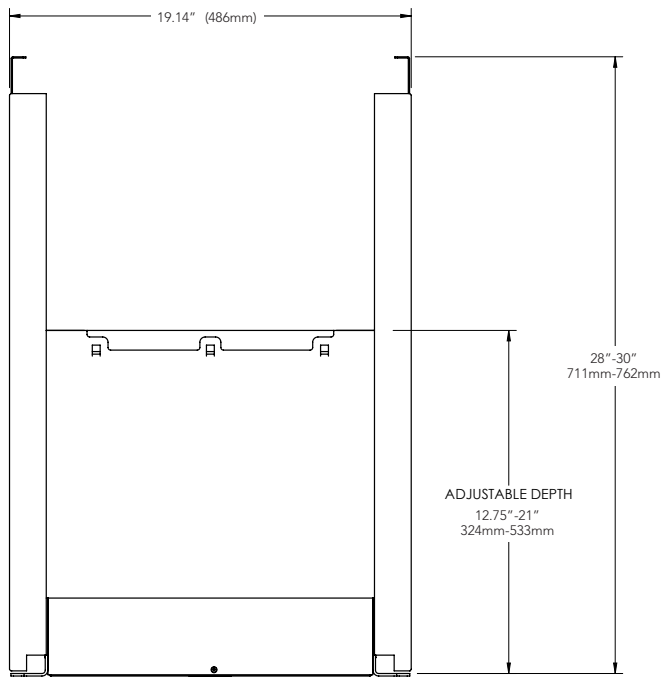

888.982.7800

www.upsite.com